

**MATERIAL**

Phenolic based (PF) Duroplast, black colour, glossy finish.

**STANDARD EXECUTIONS**

- **VL.155-A:** black-oxide steel boss, plain blind hole.
- **VL.155-B:** brass boss, plain or threaded blind hole.
- **VL.155-p:** zinc-plated steel threaded stud, chamfered flat end according to UNI 947 : ISO 4753 (see Technical data on page A-11).



ELESA Original design

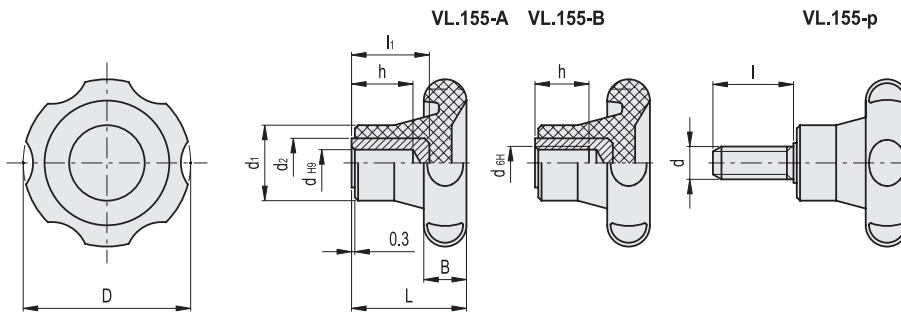

**VL.155-A**

**METRIC**

Code	Description	D	d <sub>6H</sub>	L	B	d <sub>1</sub>	d <sub>2</sub>	l <sub>1</sub>	h	△
75001	VL.155/50 A-6	51	6	34	13	23	15	23	18	57
75101	VL.155/60 A-6	61	6	38	16	25	15	23	18	81
75211	VL.155/70 A-8	69	8	42	18	27	18	28	21	115
75221	VL.155/70 A-10	69	10	42	18	27	18	31	25	110
75301	VL.155/80 A-8	82	8	48	19	33	20	35	26	177
75311	VL.155/80 A-10	82	10	48	19	33	18	31	25	170
75321	VL.155/80 A-12	82	12	48	19	33	18	29	23	165
75401	VL.155/100 A-8	99	8	52	20	36	26	36	25	275

**VL.155-B**

Code	Description	D	d <sub>6H</sub>	d <sub>H9</sub>	L	B	d <sub>1</sub>	d <sub>2</sub>	l <sub>1</sub>	h	△
75011	VL.155/50 B-6	51	-	6	34	13	23	15	23	18	58
75021	VL.155/50 B-M8	51	M8	-	34	13	23	-	-	13	41
75111	VL.155/60 B-6	61	-	6	38	16	25	15	23	18	82
75121	VL.155/60 B-M8	61	M8	-	38	16	25	-	-	20	66
75131	VL.155/60 B-M10	61	M10	-	38	16	25	-	-	17	68
75231	VL.155/70 B-6	69	-	6	42	18	27	18	28	20	120
75241	VL.155/70 B-M10	69	M10	-	42	18	27	-	-	17	85
75251	VL.155/70 B-M12	69	M12	-	42	18	27	-	-	20	90
75331	VL.155/80 B-8	82	-	8	48	19	33	20	35	26	183

**VL.155-p**

**METRIC**

Code	Description	D	d <sub>6g</sub>	L	B	d <sub>1</sub>	l	△
75031	VL.155/50 p-M8x25	51	M8	34	12	23	25	48
75032	VL.155/50 p-M8x40	51	M8	34	12	23	40	52
75041	VL.155/50 p-M10x30	51	M10	34	12	23	30	62
75042	VL.155/50 p-M10x50	51	M10	34	12	23	50	73
75141	VL.155/60 p-M8x30	61	M8	38	16	25	30	77
75151	VL.155/60 p-M10x30	61	M10	38	16	25	30	82
75261	VL.155/70 p-M10x30	69	M10	42	18	27	30	100
75262	VL.155/70 p-M10x50	69	M10	42	18	27	50	110
75271	VL.155/70 p-M12x25	69	M12	42	18	27	25	110
75272	VL.155/70 p-M12x50	69	M12	42	18	27	50	135
75341	VL.155/80 p-M12x30	82	M12	48	19	33	30	155
75342	VL.155/80 p-M12x50	82	M12	48	19	33	50	180

Conversion Table	
1 mm = 0.039 inch	
D	
mm	inch
51	2.01
61	2.40
69	2.72
82	3.23
99	3.90

